

COME HOME TO

CROCK·POT®

LIFT & SERVE ONE POT SLOW COOKER

CHP550

User Guide



Contents

Safety Precautions	1
Features of your One Pot Cooker	2
Introduction to One Pot Cooking	3
Using your One Pot Cooker	3
Hints and Tips	4
Care and Cleaning	4

Important instructions – retain for future use.

تأكد من تفهم احتياطات السلامة المذكورة اعلاه

請務必理解上述的安全預防措施。

Assurez-vous que les précautions ci-dessus relatives à la sécurité sont bien comprises

Versichern Sie sich, dass die obenstehenden Sicherheitsmaßnahmen Verstanden werden

Βεβαιώσετε πως οι παραπάνω προφυλάξεις ασφαλείας γίνονται κατανοητές

Pastikan bahwa tindakan-tindakan keselamatan seperti di atas dimengerti anda

Accertatevi che le suddette norme di sicurezza siano comprese a dovere

上記の注意事項をよくお読みになり、安全を御確認ください

Уверете се дека погоре споменатите мерки на претпазливост се добро разбрани

Asegúrese de que las precauciones de seguridad precedentes sean bien comprendidas

کاری بکنید کہ احتیاطهای بالا حتماً درک بشوند

ต้องแน่ใจว่า ข้อควรระวังเรื่องความปลอดภัยข้างต้น เป็นที่เข้าใจกันดี

Yukarda belirtilen güvenlik önlemlerinin anlaşılığından emin olunuz

Xin kiểm chắc rằng những biện pháp làm an toàn kể trên được hiểu rõ

Safety Precautions

SAFETY PRECAUTIONS FOR YOUR ONE POT COOKER

- Do not operate the cooker on an inclined surface or in confined spaces.
- Do not move or cover the cooker while in operation and use well away from walls and curtains.
- Do not immerse the base of the cooker in water or any other liquid.
- Do not touch any metal surface of the cooker whilst in use as it will be hot and subject to residual heat after use.
- Do not operate cooker when placed directly onto a bench top. Place a heat proof mat or chopping board underneath to protect the surface.

Crock-Pot is very safety conscious when designing and manufacturing consumer products, but it is essential that the product user also exercise care when using an electrical appliance. Listed below are precautions which are essential for the safe use of an electrical appliance:

- Read carefully and save all the instructions provided with an appliance.
- Always turn the power off at the power outlet before you insert or remove a plug. Remove by grasping the plug - do not pull on the cord.
- Turn the power off and remove the plug when the appliance is not in use and before cleaning.
- Do not use your appliance with an extension cord unless this cord has been checked and tested by a qualified technician or service person.
- Always use your appliance from a power outlet of the voltage (A.C. only) marked on the appliance.
- This appliance is not intended for use by persons (including children) with reduced physical, sensory or mental capabilities, or lack of experience and knowledge, unless they have been given supervision or instruction concerning use of the appliance by a person responsible for their safety.
- Children should be supervised to ensure that they do not play with the appliance.
- The temperature of accessible surfaces may be high when the appliance is operating.
- Never leave an appliance unattended while in use.
- Do not use an appliance for any purpose other than its intended use to avoid injury.
- Do not place an appliance on or near a hot gas flame, electric element or on a heated oven.
- Do not place on top of any other appliance.
- Do not let the power cord of an appliance hang over the edge of a table or bench top or touch any hot surface.
- Do not operate any electrical appliance with a damaged cord or after the appliance has been damaged in any manner. If damage is suspected, return the appliance to the nearest Crock-Pot Appointed Service Centre for examination, repair or adjustment.
- Appliance should be supplied through a residual current device (RCD) having a rated residual operating current not exceeding 30 mA.
- Do not immerse the appliance in water or any other liquid unless recommended.
- Appliances are not intended to be operated by means of an external timer or separate remote control system.
- This appliance is intended to be used in household and similar applications such as: staff kitchen areas in shops, offices and other working environments; farm houses; by clients in hotels, motels and other residential type environments; bed and breakfast type environments.
- Power cord should be regularly examined for signs of damage and appliance should not be used if damaged.

If you have any concerns regarding the performance and use of your appliance, please visit www.crockpot.com.au or contact the Crock-Pot Consumer Service Line.

Ensure the above safety precautions are understood.

Features of your One Pot Cooker

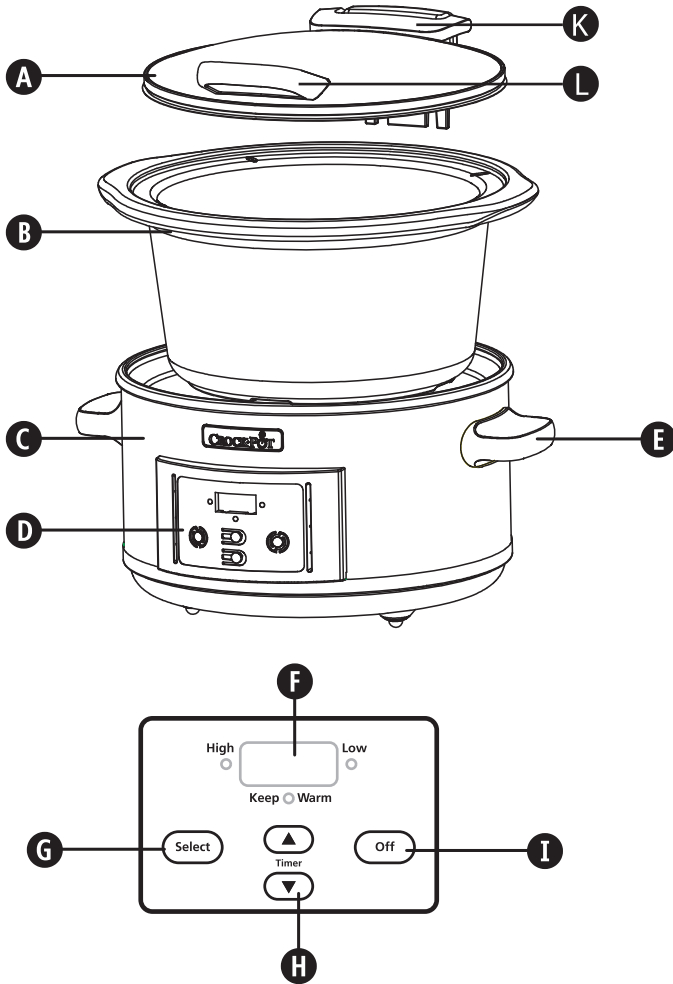

- A** Glass lid
- B** Crock insert
- C** Heating base
- D** Control panel
- E** Carrying handles
- F** Time setting display

- G** Temperature select button
- H** Timer up/down buttons
- I** Standby button
- J** Power cord (not shown)
- K** Lid hinge
- L** Lid lifting handle

Introduction to One Pot Cooking

We believe serving nutritious, delicious, tender and affordable meals to family and friends should be easy.

Save time and effort by simply preparing ingredients, popping them all into the pot and setting the timer. It's easy!

But Crock-Pot isn't just for dinner time. Create snacks, desserts and even breakfast with this true one-pot cooker. Visit our website to discover the possibilities and to write a review of your one pot cooker.

Using your One Pot Cooker

Note: When using the cooker for the first time you may notice a fine smoke haze being emitted from the unit. This is normal and is due to the initial heating of internal components.

1. Before using your Crock-Pot one pot cooker for the first time, remove the crock insert and lid and wash them in warm soapy water. Rinse and dry thoroughly and replace.
2. Place the cooker on a flat level surface.
3. Prepare the food to be cooked and place inside the crock. Attach the lid by inserting the hinge mechanism into the hinge slot at the rear of the heating base.
4. Insert the plug into a 230-240V power outlet and turn the power ON.
5. Select the desired setting using the Temperature Select Button **G**. The high temperature light or low temperature light will come on.

6. Press the Timer Up/Down buttons **H** to select a cooking time. Time can be set in 30 minute increments up to 20 hours.
7. When the timer has finished, the cooker will automatically switch to Keep Warm setting.
8. To stop cooking, press the Standby Button **I**. To turn the cooker off unplug from power supply.

Note: If the mains power has been interrupted (power cut), the display and lights will flash when power is restored. All the slow cooker settings will be lost, as a result the food may be unsafe to eat.

Important: Food should not be cooked on Keep Warm setting as this will not get hot enough to cook. This setting should only be used to keep hot, cooked food warm for serving.

Note: The crock cannot be removed from the heating base without first detaching the lid by lifting it out of the hinge slot.

Important: Maximum food capacity is 1.3kg whole piece of meat.

Hints and Tips

- When cooking with vegetables, place them in the crock insert first, and then place the meat on top.
- Always ensure that food or liquid comes to at least half way up the wall of the crock insert, as the element is located on the sides of the cooker.
- When roasting whole pieces of lamb, beef or chicken, it is not necessary to add liquid. Pot roasts and corned meats should be barely covered with liquid.
- Do not use oven bags in your one pot cooker.
- Frozen foods can be placed in the cold cooker and heated for 5-8 hours, depending on the quantity. Do not place frozen food into a heated cooker.
- If a recipe results in too much liquid, turn the one pot cooker to the HIGH setting, remove the lid and cook until sufficient liquid has evaporated.
- To thicken a sauce, set the cooker to the HIGH setting and stir through a thickening agent such as cornflour combined with a little water. Allow to simmer until thickened, stirring occasionally.
- Stirring is rarely necessary, as the element wraps around the sides of the cooker, preventing the food from sticking to the base.
- Leave the lid on the cooker during cooking to maintain heat and moisture.

Part	Dishwasher Safe	Oven Safe	Microwave Safe	Hob Safe
Lid	Yes	No	No	No
Crock	Yes	Yes	Yes	No

Care and Cleaning

Wash the crock insert and lid in hot soapy water. To remove food that is cooked onto the bottom, soak the crock insert in warm water before cleaning and scrub lightly with a plastic or nylon brush. Rinse well and dry. The crock insert and lid are also dishwasher safe for added convenience.

Note: Do not place the hot crock insert under cold water.

Wipe the exterior of the cooker with a damp cloth and polish dry. **DO NOT** use harsh abrasives, scourers, alkaline cleaners or chemicals to clean any part of your cooker as these will damage the surfaces.

CAUTION: Do not immerse the base of the cooker in water or any other liquid.

12 Month Replacement Guarantee

This product is covered by a 12 month replacement or repair warranty, which is in addition to your rights under the Australian Consumer Law (if your product was purchased in Australia) or New Zealand Consumer Guarantees Act (if your product was purchased in New Zealand).

Upon receipt of your claim, Sunbeam will seek to resolve your difficulties or, if the product is defective, advise you on how to obtain a replacement or refund.

To assist us in managing warranty claims, we recommend you register your product as soon as practicable after purchase by creating a MySunbeam account on our website and uploading a copy of your original receipt.

In order to make a claim under our warranty, you must have the original proof of purchase documentation for the product and present it when requested (if not already uploaded to our website).

Should your product develop any defect within 12 months of purchase because of faulty materials or workmanship, we will replace or repair it, at our discretion, free of charge. A product presented for repair may be replaced by a refurbished product of the same type rather than being repaired. Refurbished parts may be used to repair the product.

Our replacement or repair warranty only applies where a defect arises as a result of faulty material or workmanship during the warranty period. Your warranty does not cover misuse or negligent handling (including damage caused by failing to use the product in accordance with this instruction booklet), accidental damage, or normal wear and tear.

Your warranty does not:

- cover freight or any other costs incurred in making a claim, consumable items, accessories that by their nature and limited lifespan require periodic renewal (such as filters and seals) or any consequential loss or damage; or
- cover damage caused by:
 - power surges, power dips, voltage supply problems, or use of the product on incorrect voltage;

- servicing or modification of the product other than by Sunbeam or an authorised Sunbeam service centre;
- use of the product with other accessories, attachments, product supplies, parts or devices that do not conform to Sunbeam specifications; or
- exposure of the product to abnormally corrosive conditions; or

- extend beyond 3 months if the product is used in commercial, industrial, educational or rental applications.

The benefits given to you by our warranty are in addition to other rights and remedies under law in relation to the product.

In Australia our goods come with guarantees that cannot be excluded under the Australian Consumer Law. You are entitled to a replacement or refund for a major failure and for compensation for any other foreseeable loss or damage. You are also entitled to have the goods repaired or replaced if the goods fail to be of acceptable quality and the failure does not amount to a major failure.

Our goods also come with guarantees that cannot be excluded under the New Zealand Consumer Guarantees Act.

If your warranty claim is not accepted, we will inform you and if requested to do so by you, repair the product provided you pay the usual charges for such repair. You will also be responsible for all freight and other costs.

Should your product require repair or service after the warranty period, contact your nearest Sunbeam service centre. For a complete list of Sunbeam's service centres, visit our website or call our customer service line for advice on 1300 881 861 in Australia, or 0800 786 232 in New Zealand.

Should you experience any difficulties with your product during the warranty period, please contact our customer service line for advice on 1300 881 861 in Australia, or 0800 786 232 in New Zealand.

Australia

www.crockpot.com.au
1300 881 861
Units 5 & 6,
13 Lord Street,
Botany NSW 2019
Australia

New Zealand

www.crockpot.co.nz
0800 786 232
Level 6, Building 5,
Central Park,
660-670 Great South Road,
Greenlane, Auckland
New Zealand

Need help with your appliance?

Contact our customer service team or visit our website for information and tips on getting the most from your appliance.

Australia | **visit** www.crockpot.com.au
phone 1300 881 861
mail Units 5 & 6, 13 Lord Street,
Botany NSW 2019 Australia.

New Zealand | **visit** www.crockpot.co.nz
phone 0800 786 232
mail Level 6, Building 5,
Central Park,
660-670 Great South Road,
Greenlane, Auckland.

Sunbeam Corporation PTY LTD | ACN 000 006 771

Crock-Pot is a registered trademark.

Made in China to Sunbeam's specification.

Due to minor changes in design or otherwise,
the product you buy may differ slightly from the one shown here.
Approved by the appropriate electrical regulatory authorities.

©Copyright Sunbeam 2019.

6/18

3741-IB

CSH-SL0318-SUN186616